



Ice Cream Freezer Catalogue



scandomestic

Why Choose Scandomestic.....

Quality and reliability

- *We partner with the world's leading manufacturers.*

Full service and support

- *In-house service department and spare parts warehouse.*

Over 300 years of combined experience

- *A strong team of appliance specialists.*

Fast delivery from a large warehouse

- *Constant stock of 30–35,000 units in Silkeborg.*

Sustainable and responsible solutions

- *We set high standards for environment, health, safety, and ethical production.*

Solutions for the future

- *Innovative household appliances and professional cooling solutions for every need.*



Scoop Ice Freezers

General features

- Exceptionally energy-efficient models
- Curved glass sneeze guard for hygienic customer-facing presentation
- Sliding glass lids with integrated lock for secure overnight storage
- Internal LED lighting and front LED branding strip for high visibility
- Robust castors (2 with brake) for mobility and stability
- Static cooling system – ideal for stable temperature and silent operation
- Perfect for branding and impulse sales in cafés, kiosks, and events





Built to Perform – and Promote

This scoop ice cream freezer features a robust cabinet designed for daily commercial use.

It is equipped with strong castors, making it easy to move and position, even when fully loaded.

The side panels offer additional space for branding, providing excellent visibility and promotional opportunities from multiple angles



Additional Storage

The freezer includes a compartment that provides additional storage space for ice cream, equipped with a strong handle for easy access.

This is ideal for quick refilling during the day, ensuring continuous service without the need to leave the sales area.



Fits Napoli Standard 5L Pans

Scoop ice freezers are built for Napoli 5L standard pans, ensuring full compatibility with industry norms.

Models are available in 4, 6, 9, or 12-pan setups – perfect for everything from small kiosks to full-size gelato counters.



Ice Cream Freezer

Scancool, SIC4WB



Dimensions and weight

| | |
|---------------------------------|-------------------|
| Product dimensions, HxWxD, mm | 1270 x 836 x 838 |
| Product depth w/handle, mm | 838 |
| Packaging dimensions, HxWxD, mm | 1310 x 965 x 1005 |
| Gross volume, L | 235 |
| Net volume, L | 170 |
| Gross- / Net volume, L | 235 / 170 |
| Internal dimensions, HxWxD, mm | 600 x 656 x 550 |
| Gross- / Net weight, kg | 108 / 82 |

Performance and consumption

| | |
|------------------------------------|------------|
| Energy efficiency class | A |
| Daily Energy Consumption, kWh/24 | 2,465 |
| Annual energy cons. kWh/a | 899,73 |
| Energy Efficiency Index (EEl) | 7,5 |
| Refrigeration / freezing technique | Static |
| Climate class | 4 |
| Type of refrigerant / gas gr. | R290a / 68 |
| Bulb Watt, W | 12 |
| Temperature range °C | -18 / -24 |

Installation and power

| | |
|--------------------------|-----------------|
| Voltage / hertz, V/hz | 220-240V / 50hz |
| No. of electrical phases | 1L+N |
| Watt / Ampere, W/A | 130 / 1 |
| Peak power watt, W | 200 |
| Length of Powercord, cm | 200 |

Design and comfort

| | |
|------------------------|-----------------------|
| Controller | Mechanical |
| Control panel | Outside |
| Digital display | No |
| Internal light | 1 Horizontal LED |
| External thermometer | Yes |
| Door- / lid type | Sliding |
| Handle | Outside |
| Number of castors, pcs | 4 casters (2 w/brake) |
| Lock & Key | Yes |

Colour and material

| | |
|---------------------------------|---------------|
| Outside colour | White |
| Inside Colour | White |
| Colour and material of door/lid | Sliding glass |

Features

| | |
|---------------|-----|
| Night curtain | Yes |
|---------------|-----|



| | | | |
|-------------|-------------------|------------------|------------|
| Item number | 23424510000SIC4WB | Taric goods code | 8418501190 |
| EAN code | 5704704022492 | QTY in 40HQ | 47 |

Short Description

Inside, it includes a full set of stainless steel 5L Napoli pans, and there's additional storage space below the pans, accessible via a separate rear door – ideal for backup stock or accessories.

Built-in LED lighting inside and on the front ensures a striking product display and offers branding opportunities on the front panel.

Equipped with strong castors, two of which have brakes, the unit is easy to move and stays stable during use.

Key features

- Curved glass sneeze guard for hygiene
- Sliding glass lids with integrated lock for secure overnight storage
- Includes full set of 4 pcs. 5L Napoli stainless steel pans
- Extra storage under pans with separate rear door
- Internal LED light and front LED for branding
- Strong castors, 2 with brake
- Static cooling - Energy class A –efficient performance
- Ideal for cafés, kiosks, and promotional use

Measurement drawing

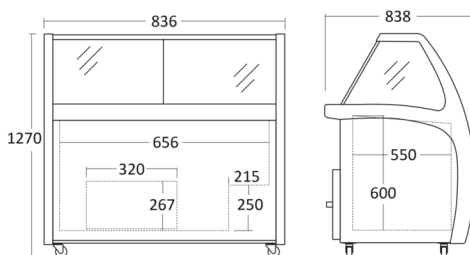



Scoop Ice Freezer

Scancool - SIC6WBL



Dimensions and weight

| | |
|---------------------------------|--------------------|
| Product dimensions, HxWxD, mm | 1270 x 1080 x 838 |
| Packaging dimensions, HxWxD, mm | 1310 x 1210 x 1005 |
| Gross volume, L | 300 |
| Gross- / Net volume, L | 300 / |
| Internal dimensions, HxWxD, mm | 402 x 900 x 550 |

Performance and consumption

| | |
|------------------------------------|------------|
| Energy efficiency class | A |
| Daily Energy Consumption, kWh/24 | 3 |
| Annual energy cons. kWh/a | 1100 |
| Energy Efficiency Index (EEI) | 8,5 |
| Refrigeration / freezing technique | Static |
| Climate class | 4 |
| Type of refrigerant / gas gr. | R290a / 98 |
| Bulb Watt, W | 12 |
| Temperature range °C | -18 / -24 |

Installation and power

| | |
|--------------------------|-----------------|
| Voltage / hertz, V/hz | 220-240V / 50hz |
| No. of electrical phases | 1L+N |
| Watt / Ampere, W/A | 180 / 1.5 |
| Peak power watt, W | 280 |
| Length of Powercord, cm | 200 |

Design and comfort

| | |
|------------------------|-----------------------|
| Controller | Digital |
| Control panel | Outside |
| Digital display | Yes |
| Internal light | 1 Horizontal LED |
| External thermometer | Yes |
| Door- / lid type | Sliding |
| Handle | Outside |
| Number of castors, pcs | 4 casters (2 w/brake) |
| Lock & Key | Yes |

Colour and material

| | |
|---------------------------------|---------------|
| Outside colour | White |
| Inside Colour | White |
| Colour and material of door/lid | Sliding glass |

Features



| | | | | |
|----------|-------------|--------------------|------------------|------------|
| Eprel ID | Item number | 23424510000SIC6WBL | Taric goods code | 8418501190 |
| 2508894 | EAN code | 5704704022973 | QTY in 40HQ | 39 |

Short Description

Temperature range from -6°C to -25°C – ideal for maintaining creamy, ready-to-serve ice cream consistency.

The interior of the counter contains a complete set of 6 stainless steel 5L Naples canteens

Key features

- Includes full set of 6 pcs, 5L Napoli stainless steel pans
- Rear storage with room for 10 filled pans
- Internal LED light and front LED light for branding
- Strong castors, 2 of which have brakes
- Sliding glass lids with integrated lock
- Curved front glass for hygiene and nice presentation.
- Static cooling - efficient performance
- Ideal for cafés, kiosks, and ice cream shops

Measurement drawing

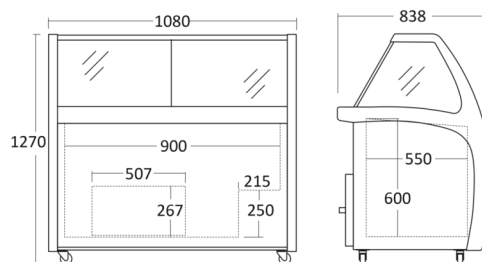



Scoop Ice Freezer

Scancool - SIC9WBL



Dimensions and weight

| | |
|---------------------------------|--------------------|
| Product dimensions, HxWxD, mm | 1270 x 1350 x 838 |
| Product depth w/handle, mm | 838 |
| Packaging dimensions, HxWxD, mm | 1310 x 1480 x 1005 |
| Gross volume, L | 400 |
| Gross- / Net volume, L | 400 / |
| Internal dimensions, HxWxD, mm | 411 x 1170 x 550 |

Performance and consumption

| | |
|------------------------------------|-------------|
| Energy efficiency class | A |
| Daily Energy Consumption, kWh/24 | 3,795 |
| Annual energy cons. kWh/a | 1385 |
| Energy Efficiency Index (EEL) | 9,2 |
| Refrigeration / freezing technique | Static |
| Climate class | 4 |
| Type of refrigerant / gas gr. | R290a / 105 |
| Bulb Watt, W | 12 |
| Temperature range °C | -15 / -24 |

Installation and power

| | |
|--------------------------|-----------------|
| Voltage / hertz, V/hz | 220-240V / 50hz |
| No. of electrical phases | 1L+N |
| Watt / Ampere, W/A | 180 / 1.5 |
| Peak power watt, W | 280 |
| Length of Powercord, cm | 200 |

Design and comfort

| | |
|------------------------|-----------------------|
| Controller | Digital |
| Control panel | Outside |
| Digital display | Yes |
| Internal light | 1 Horizontal LED |
| External thermometer | Yes |
| Door- / lid type | Sliding |
| Handle | Outside |
| Number of castors, pcs | 4 castors (2 w/brake) |
| Lock & Key | Yes |

Colour and material

| | |
|---------------------------------|---------------|
| Outside colour | White |
| Inside Colour | White |
| Colour and material of door/lid | Sliding glass |

Features



| | | | | |
|----------|-------------|--------------------|------------------|------------|
| Eprel ID | Item number | 23424510000SIC9WBL | Taric goods code | 8418501190 |
| 2508925 | EAN code | 5704704022980 | QTY in 40HQ | 31 |

Short Description

Temperature range from -6°C to -25°C – ideal for maintaining creamy, ready-to-serve ice cream consistency.

The interior of the counter contains a complete set of 9 stainless steel 5L Naples canteens

Key features

- Includes full set of 9 pcs, 5L Napoli stainless steel pans
- Rear storage with room for 14 filled pans
- Internal LED light and front LED light for branding
- 4 strong wheels, 2 of which have brakes.
- Curved front glass for hygiene and nice presentation.
- Sliding glass lids with integrated lock
- Static cooling - efficient performanc
- Ideal for cafés, kiosks, and ice cream shops.

Measurement drawing

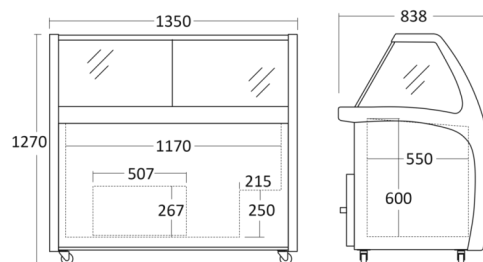



Scoop Ice Freezer

Scancool - SIC12WBL



Dimensions and weight

| | |
|---------------------------------|--------------------|
| Product dimensions, HxWxD, mm | 1270 x 1720 x 838 |
| Packaging dimensions, HxWxD, mm | 1320 x 1850 x 1005 |
| Gross volume, L | 535 |
| Gross- / Net volume, L | 535 / |
| Internal dimensions, HxWxD, mm | 402 x 1540 x 550 |

Performance and consumption

| | |
|------------------------------------|-------------|
| Energy efficiency class | B |
| Daily Energy Consumption, kWh/24 | 4,849 |
| Annual energy cons. kWh/a | 1770 |
| Energy Efficiency Index (EEI) | 10,4 |
| Refrigeration / freezing technique | Static |
| Climate class | 4 |
| Type of refrigerant / gas gr. | R290a / 120 |
| Bulb Watt, W | 25 |
| Temperature range °C | -15 / -24 |

Installation and power

| | |
|--------------------------|-----------------|
| Voltage / hertz, V/hz | 220-240V / 50hz |
| No. of electrical phases | 1L+N |
| Watt / Ampere, W/A | 255 / 2 |
| Peak power watt, W | 400 |
| Length of Powercord, cm | 200 |

Design and comfort

| | |
|------------------------|-----------------------|
| Controller | Digital |
| Control panel | Outside |
| Digital display | Yes |
| Internal light | 1 Horizontal LED |
| External thermometer | Yes |
| Door- / lid type | Sliding |
| Handle | Outside |
| Number of castors, pcs | 4 casters (2 w/brake) |
| Lock & Key | Yes |

Colour and material

| | |
|---------------------------------|---------------|
| Outside colour | White |
| Inside Colour | White |
| Colour and material of door/lid | Sliding glass |

Features



| | | | | |
|----------|-------------|---------------------|------------------|------------|
| Eprel ID | Item number | 23424510000SIC12WBL | Taric goods code | 8418501190 |
| 2508939 | EAN code | 5704704022959 | QTY in 40HQ | 23 |

Short Description

Temperature range from -6°C to -25°C – ideal for maintaining creamy, ready-to-serve ice cream consistency.

The interior of the counter contains a complete set of 4 stainless steel 5L Naples canteens

Key features

- Includes full set of 12 pcs, 5L Napoli stainless steel pans
- Rear storage with room for 20 filled pans
- 4 strong wheels, 2 of which have brakes
- Curved front glass for hygiene and nice presentation
- Internal LED light and front LED light for branding
- Static cooling – efficient performance
- Sliding glass lids with integrated lock
- Perfect for cafés, kiosks, and ice cream shops

Measurement drawing

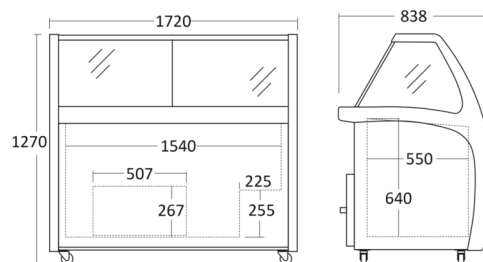

Ice Cream Freezers

General features

- Transparent sliding lids with lock and integrated handle for better cold retention
- Freezing range from -18°C to -24°C
- ideal for storing and displaying ice cream
- 4 strong wire baskets with 2 dividers in each for flexible organization
- White lacquered steel inner liner and design with soft, rounded corners
- Equipped with 4 heavy-duty castors
- easy to move even when fully loaded
- Suitable for side branding with optional lightbox accessory
- Effective product presentation that promotes self-service, visibility, and increased sales
- Climate class 7 – reliable operation even in warm environments





Ice Cream Freezer

Scancool, IC155D



Dimensions and weight

| | |
|---------------------------------|-----------------|
| Product dimensions, HxWxD, mm | 865 x 585 x 700 |
| Product depth w/handle, mm | 700 |
| Packaging dimensions, HxWxD, mm | 880 x 625 x 770 |
| Gross volume, L | 137 |
| Net volume, L | 94 |
| Gross- / Net volume, L | 137 / 94 |
| Internal dimensions, HxWxD, mm | 500 x 440 x 550 |
| Gross- / Net weight, kg | 53 / 48 |

Performance and consumption

| | |
|------------------------------------|------------|
| Energy efficiency class | D |
| Daily Energy Consumption, kWh/24 | 1,21 |
| Annual energy cons. kWh/a | 440 |
| Energy Efficiency Index (EEl) | 41,13 |
| Noise level, dB(A) | 70 |
| Refrigeration / freezing technique | Static |
| Climate class | 7 |
| Temperature class | C1 |
| Type of refrigerant / gas gr. | R290a / 60 |
| Bulb Watt, W | None |
| Temperature range °C | -18 / -24 |
| NoFrost | No |

Installation and power

| | |
|--------------------------|-----------------|
| Voltage / hertz, V/hz | 220-240V / 50hz |
| No. of electrical phases | 1L+N |
| Watt / Ampere, W/A | 200 / 1.5 |
| Peak power watt, W | 230 |
| Length of Powercord, cm | 200 |

Design and comfort

| | |
|------------------------|------------------------------|
| Controller | Mechanical |
| Control panel | Outside |
| Digital display | No |
| Canopy light sign | No - available as spare part |
| Internal light | No light |
| External thermometer | Yes |
| Door- / lid type | Sliding |
| Handle | Integrated |
| Number of castors, pcs | 4 castors (2 w/brake) |
| Lock & Key | Yes |

Colour and material

| | |
|---------------------------------|---------------|
| Outside colour | White |
| Inside Colour | White |
| Colour and material of door/lid | Sliding glass |

Features

| | |
|----------------------------------|-----|
| Number of baskets, pcs | 2 |
| Basket Size (HxWxD) (mm) | Yes |
| Max loading per shelf/basket, kg | 15 |

| | | | |
|-------------|-------------------|------------------|------------|
| Item number | 23424310000IC155D | Taric goods code | 8418501190 |
| EAN code | 5704704019515 | QTY in 40HQ | 169 |



Short Description

The IC155D holds 94 ltr. freezing capacity, it also comes with lightweight sliding lids and are therefore suitable for self-service, which provides a good opportunity to place the cabinet strategically to create focus and additional sales.

Key features

- Curved sliding glass lids
- 2 strong wire baskets including 2 dividers in each
- 4 strong castors
- Suitable for branding
- Light sign sold separately
- Coated white steel inner liner

Measurement drawing

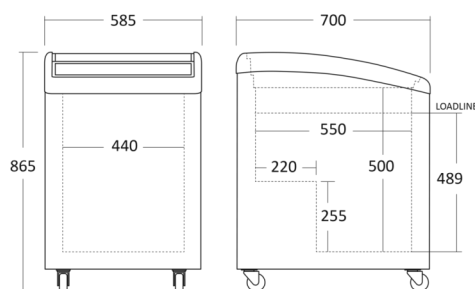

SCANCOOL



Ice Cream Freezer

Scancool, IC306D



Dimensions and weight

| | |
|---------------------------------|------------------|
| Product dimensions, HxWxD, mm | 850 x 1025 x 649 |
| Product depth w/handle, mm | 649 |
| Packaging dimensions, HxWxD, mm | 895 x 1080 x 730 |
| Gross volume, L | 255 |
| Net volume, L | 192 |
| Gross- / Net volume, L | 255 / 192 |
| Internal dimensions, HxWxD, mm | 645 x 856 x 505 |
| Gross- / Net weight, kg | 68 / 60 |

Performance and consumption

| | |
|------------------------------------|------------|
| Energy efficiency class | D |
| Daily Energy Consumption, kWh/24 | 1,64 |
| Annual energy cons. kWh/a | 600 |
| Energy Efficiency Index (EEl) | 42,14 |
| Noise level, dB(A) | 70 |
| Refrigeration / freezing technique | Static |
| Climate class | 7 |
| Temperature class | C1 |
| Type of refrigerant / gas gr. | R290a / 66 |
| Temperature range °C | -18 / -24 |
| NoFrost | No |

Installation and power

| | |
|--------------------------|-----------------|
| Voltage / hertz, V/hz | 220-240V / 50hz |
| No. of electrical phases | 1L+N |
| Watt / Ampere, W/A | 180 / 2 |
| Peak power watt, W | 280 |
| Length of Powercord, cm | 200 |

Design and comfort

| | |
|------------------------|-----------------------|
| Controller | Mechanical |
| Control panel | Outside |
| Digital display | No |
| Internal light | No light |
| External thermometer | Yes |
| Door- / lid type | Sliding |
| Handle | Integrated |
| Number of castors, pcs | 4 castors (2 w/brake) |
| Lock & Key | Yes |

Colour and material

| | |
|---------------------------------|---------------|
| Outside colour | White |
| Inside Colour | White |
| Colour and material of door/lid | Sliding glass |

Features

| | |
|----------------------------------|----|
| Number of baskets, pcs | 4 |
| Max loading per shelf/basket, kg | 20 |



| | | | |
|-------------|-------------------|------------------|------------|
| Item number | 23424310000IC306D | Taric goods code | 8418501190 |
| EAN code | 5704704019522 | QTY in 40HQ | 98 |

Short Description

Freezer function from -18°C to -24°C, as a freezer display case, it is ideal for storing ice cream.

4 strong wire baskets with 2 partitions in each are included.

The freezer has 4 wheels and is easy to move around, even if it is full.

The design is top class with soft and round corners.

The ice cream freezer comes with curved transparent sliding lids with an integrated handle that keeps the cold extra.

Key features

- Curved sliding glass lids with lock
- 4 strong wire baskets including 2 dividers in each
- Coated white steel inner liner
- 4 strong castors
- Suitable for branding

Measurement drawing

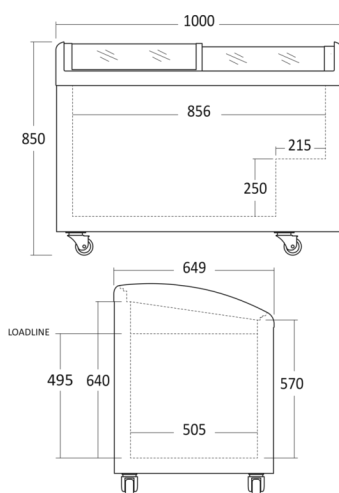

SCANCOOL



Ice Cream Freezer

Scancool, IC352D



Dimensions and weight

| | |
|---------------------------------|------------------|
| Product dimensions, HxWxD, mm | 850 x 1240 x 649 |
| Product depth w/handle, mm | 649 |
| Packaging dimensions, HxWxD, mm | 895 x 1310 x 735 |
| Gross volume, L | 330 |
| Net volume, L | 251 |
| Gross- / Net volume, L | 330 / 251 |
| Internal dimensions, HxWxD, mm | 640 x 1080 x 505 |
| Gross- / Net weight, kg | 79 / 68 |

Performance and consumption

| | |
|------------------------------------|------------|
| Energy efficiency class | D |
| Daily Energy Consumption, kWh/24 | 1,86 |
| Annual energy cons. kWh/a | 680 |
| Energy Efficiency Index (EEl) | 41,54 |
| Noise level, dB(A) | 70 |
| Refrigeration / freezing technique | Static |
| Climate class | 7 |
| Temperature class | C1 |
| Type of refrigerant / gas gr. | R290a / 80 |
| Temperature range °C | -18 / -24 |
| NoFrost | No |

Installation and power

| | |
|--------------------------|-----------------|
| Voltage / hertz, V/hz | 220-240V / 50hz |
| No. of electrical phases | 1L+N |
| Watt / Ampere, W/A | 180 / 2.2 |
| Peak power watt, W | 280 |
| Length of Powercord, cm | 200 |

Design and comfort

| | |
|------------------------|-----------------------|
| Controller | Mechanical |
| Control panel | Outside |
| Digital display | No |
| Internal light | No light |
| External thermometer | Yes |
| Door- / lid type | Sliding |
| Handle | Integrated |
| Number of castors, pcs | 4 castors (2 w/brake) |
| Lock & Key | Yes |

Colour and material

| | |
|---------------------------------|---------------|
| Outside colour | White |
| Inside Colour | White |
| Colour and material of door/lid | Sliding glass |

Features

| | |
|----------------------------------|-----|
| Number of baskets, pcs | 5 |
| Basket Size (HxWxD) (mm) | Yes |
| Max loading per shelf/basket, kg | 20 |



| | | | |
|-------------|-------------------|------------------|------------|
| Item number | 23424310000IC352D | Taric goods code | 8418501190 |
| EAN code | 5704704019546 | QTY in 40HQ | 81 |

Short Description

Freezer function from -18°C to -24°C, as a freezer display case, it is ideal for storing ice cream.

5 strong wire baskets with 2 partitions in each are included.

The freezer has 4 wheels and is easy to move around, even if it is full.

The design is top class with soft and round corners.

The ice cream freezer comes with curved transparent sliding lids with an integrated handle that keeps the cold extra.

Key features

- Curved sliding glass lids with lock
- 5 strong wire baskets including 2 dividers in each
- Coated white steel inner liner
- 4 strong castors
- Suitable for branding

Measurement drawing

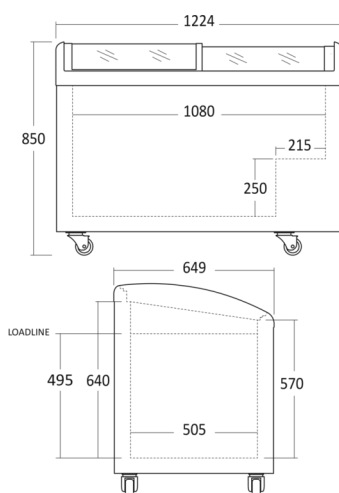



Ice Cream Freezer

Scancool, IC310D



Dimensions and weight

| | |
|---------------------------------|------------------|
| Product dimensions, HxWxD, mm | 840 x 1020 x 700 |
| Product depth w/handle, mm | 700 |
| Packaging dimensions, HxWxD, mm | 890 x 1086 x 770 |
| Gross volume, L | 284 |
| Net volume, L | 223 |
| Gross- / Net volume, L | 284 / 223 |
| Internal dimensions, HxWxD, mm | 620 x 856 x 550 |
| Gross- / Net weight, kg | 68 / 60 |

Performance and consumption

| | |
|------------------------------------|------------|
| Energy efficiency class | D |
| Daily Energy Consumption, kWh/24 | 1,63 |
| Annual energy cons. kWh/a | 595 |
| Energy Efficiency Index (EEl) | 38,74 |
| Noise level, dB(A) | 70 |
| Refrigeration / freezing technique | Static |
| Climate class | 7 |
| Type of refrigerant / gas gr. | R290a / 78 |
| Temperature range °C | -18 / -24 |
| NoFrost | No |

Installation and power

| | |
|--------------------------|-----------------|
| Voltage / hertz, V/hz | 220-240V / 50hz |
| No. of electrical phases | 1L+N |
| Watt / Ampere, W/A | 180 / 2 |
| Peak power watt, W | 280 |
| Length of Powercord, cm | 200 |

Design and comfort

| | |
|------------------------|-----------------------|
| Controller | Mechanical |
| Control panel | Outside |
| Digital display | No |
| Internal light | No light |
| External thermometer | Yes |
| Door- / lid type | Sliding |
| Handle | Integrated |
| Number of castors, pcs | 4 casters (2 w/brake) |
| Lock & Key | Yes |

Colour and material

| | |
|---------------------------------|---------------|
| Outside colour | White |
| Inside Colour | White |
| Colour and material of door/lid | Sliding glass |

Features

| | |
|----------------------------------|-----|
| Number of baskets, pcs | 4 |
| Basket Size (HxWxD) (mm) | Yes |
| Max loading per shelf/basket, kg | 20 |



| | | | |
|-------------|-------------------|------------------|------------|
| Item number | 23424310000IC310D | Taric goods code | 8418501190 |
| EAN code | 5704704019539 | QTY in 40HQ | 97 |

Short Description

Freezer function from -18°C to -24°C, as a freezer display case, it is ideal for storing ice cream.

4 strong wire baskets with 2 partitions in each are included.

The freezer has 4 wheels and is easy to move around, even if it is full. The design is top class with soft and round corners.

The ice cream freezer comes with flat transparent sliding lids with an integrated handle that keeps the cold extra.

Key features

- Flat sliding glass lids with lock
- 4 strong wire baskets including 2 dividers in each
- Coated white steel inner liner
- 4 strong castors
- Suitable for branding

Measurement drawing

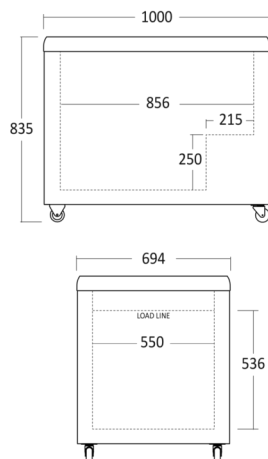



Ice Cream Freezer

Scancool, IC410D



Dimensions and weight

| | |
|---------------------------------|------------------|
| Product dimensions, HxWxD, mm | 830 x 1240 x 694 |
| Product depth w/handle, mm | 694 |
| Packaging dimensions, HxWxD, mm | 890 x 1325 x 770 |
| Gross volume, L | 372 |
| Net volume, L | 293 |
| Gross- / Net volume, L | 372 / 293 |
| Internal dimensions, HxWxD, mm | 636 x 1095 x 550 |
| Gross- / Net weight, kg | 82 / 71 |

Performance and consumption

| | |
|------------------------------------|------------|
| Energy efficiency class | D |
| Daily Energy Consumption, kWh/24 | 1,81 |
| Annual energy cons. kWh/a | 660 |
| Energy Efficiency Index (EEI) | 36,9 |
| Noise level, dB(A) | 70 |
| Refrigeration / freezing technique | Static |
| Climate class | 7 |
| Type of refrigerant / gas gr. | R290a / 92 |
| Temperature range °C | -18 / -24 |
| NoFrost | No |

Installation and power

| | |
|--------------------------|-----------------|
| Voltage / hertz, V/hz | 220-240V / 50hz |
| No. of electrical phases | 1L+N |
| Watt / Ampere, W/A | 220 / 2.5 |
| Peak power watt, W | 320 |
| Length of Powercord, cm | 200 |

Design and comfort

| | |
|------------------------|-----------------------|
| Controller | Mechanical |
| Control panel | Outside |
| Digital display | No |
| Internal light | No light |
| External thermometer | Yes |
| Door- / lid type | Sliding |
| Handle | Integrated |
| Number of castors, pcs | 4 casters (2 w/brake) |
| Lock & Key | Yes |

Colour and material

| | |
|---------------------------------|---------------|
| Outside colour | White |
| Inside Colour | White |
| Colour and material of door/lid | Sliding glass |

Features

| | |
|----------------------------------|-----|
| Number of baskets, pcs | 5 |
| Basket Size (HxWxD) (mm) | Yes |
| Max loading per shelf/basket, kg | 20 |



| | | | |
|-------------|-------------------|------------------|------------|
| Item number | 23424310000IC410D | Taric goods code | 8418501190 |
| EAN code | 5704704019553 | QTY in 40HQ | 81 |

Short Description

Freezer function from -18°C to -24°C, as a freezer display case, it is ideal for storing ice cream.

4 strong wire baskets with 2 partitions in each are included.

The freezer has 4 wheels and is easy to move around, even if it is full. The design is top class with soft and round corners.

The ice cream freezer is supplied with flat transparent sliding lids with an integrated handle that keeps the cold extra.

Key features

- Flat sliding glass lids with lock
- 4 strong wire baskets including 2 dividers in each
- Coated white steel inner liner
- 4 strong castors
- Suitable for branding

Measurement drawing

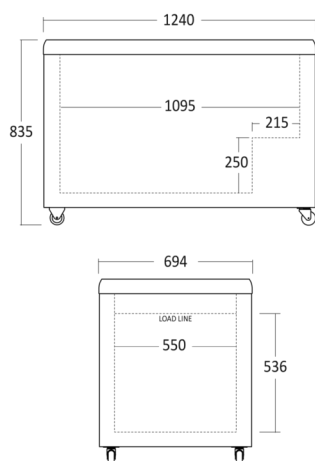



Ice Cream Freezer

Scancool, IC510D



Dimensions and weight

| | |
|---------------------------------|------------------|
| Product dimensions, HxWxD, mm | 830 x 1510 x 694 |
| Product depth w/handle, mm | 694 |
| Packaging dimensions, HxWxD, mm | 890 x 1583 x 770 |
| Gross volume, L | 473 |
| Net volume, L | 373 |
| Gross- / Net volume, L | 473 / 373 |
| Internal dimensions, HxWxD, mm | 636 x 1365 x 550 |
| Gross- / Net weight, kg | 95 / 80 |

Performance and consumption

| | |
|------------------------------------|-------------|
| Energy efficiency class | D |
| Daily Energy Consumption, kWh/24 | 2,11 |
| Annual energy cons. kWh/a | 770 |
| Energy Efficiency Index (EEl) | 37,06 |
| Noise level, dB(A) | 70 |
| Refrigeration / freezing technique | Static |
| Climate class | 7 |
| Type of refrigerant / gas gr. | R290a / 110 |
| Temperature range °C | -18 / -24 |
| NoFrost | No |

Installation and power

| | |
|--------------------------|-----------------|
| Voltage / hertz, V/hz | 220-240V / 50hz |
| No. of electrical phases | 1L+N |
| Watt / Ampere, W/A | 245 / 2.5 |
| Peak power watt, W | 370 |
| Length of Powercord, cm | 200 |

Design and comfort

| | |
|------------------------|-----------------------|
| Controller | Mechanical |
| Control panel | Outside |
| Digital display | No |
| Internal light | No light |
| External thermometer | Yes |
| Door- / lid type | Sliding |
| Handle | Integrated |
| Number of castors, pcs | 4 casters (2 w/brake) |
| Lock & Key | Yes |

Colour and material

| | |
|---------------------------------|---------------|
| Outside colour | White |
| Inside Colour | White |
| Colour and material of door/lid | Sliding glass |

Features

| | |
|----------------------------------|-----|
| Number of baskets, pcs | 6 |
| Basket Size (HxWxD) (mm) | Yes |
| Max loading per shelf/basket, kg | 20 |



| | | | |
|-------------|-------------------|------------------|------------|
| Item number | 23424310000IC510D | Taric goods code | 8418501190 |
| EAN code | 5704704019560 | QTY in 40HQ | 81 |

Short Description

Freezer function from -18°C to -24°C, as a freezer display case, it is ideal for storing ice cream.

6 strong wire baskets with 2 partitions in each are included.

The freezer has 4 wheels and is easy to move around, even if it is full. The design is top class with soft and round corners.

The ice cream freezer is supplied with flat transparent sliding lids with an integrated handle that keeps the cold extra.

Key features

- Flat sliding glass lids with lock
- 6 strong wire baskets including 2 dividers in each
- Coated white steel inner liner
- 4 strong castors
- Suitable for branding

Measurement drawing

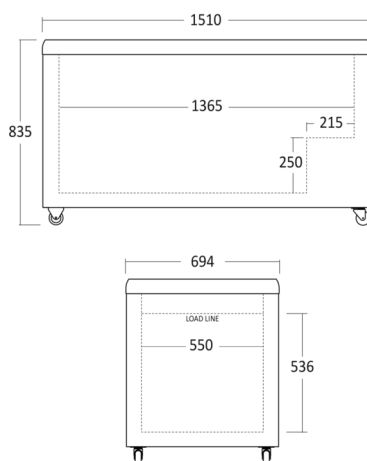

Storage Freezers

General features

- Digital controller with temperature range from -18°C to -22°C
- Strong external stainless-steel handle
- Four durable coated wire shelves plus one at the bottom (up to 30 kg capacity each)
- Reversible door with lock and removable door gasket for easy cleaning and replacement
- LED lighting with switch and ergonomic digital display for easy monitoring
- Two front feet and two rear wheels for stability and mobility
- Uses natural refrigerant R290a with low Global Warming Potential (GWP) for reduced environmental impact
- Hygienic interior with curved corners and bottom panel with water drain for faster and easier cleaning





Storage Freezer

Scancool, GUF390W



Dimensions and weight

| | |
|---------------------------------|------------------|
| Product dimensions, HxWxD, mm | 1870 x 595 x 625 |
| Product depth w/handle, mm | 655 |
| Packaging dimensions, HxWxD, mm | 2025 x 660 x 670 |
| Gross volume, L | 293 |
| Net volume, L | 293 |
| Gross- / Net volume, L | 293 / 293 |
| Internal dimensions, HxWxD, mm | 1620 x 445 x 440 |
| Gross- / Net weight, kg | 77 / 63.5 |

Performance and consumption

| | |
|------------------------------------|------------|
| Energy efficiency class | B |
| Daily Energy Consumption, kWh/24 | 2,68 |
| Annual energy cons. kWh/a | 980 |
| Energy Efficiency Index (EEl) | 33,61 |
| Noise level, dB(A) | 45 |
| Refrigeration / freezing technique | Ventilated |
| Climate class | 5 |
| Type of refrigerant / gas gr. | R290 / 45 |
| Bulb Watt, W | 20 |
| Temperature range °C | -18 / -22 |
| NoFrost | Yes |

Installation and power

| | |
|--------------------------|-----------------|
| Voltage / hertz, V/hz | 220-240V / 50hz |
| No. of electrical phases | 1L+N |
| Watt / Ampere, W/A | 135 / 1.2 |
| Peak power watt, W | 430 |
| Length of Powercord, cm | 180 |

Design and comfort

| | |
|---------------------------|-------------------------|
| Controller | Electronic |
| Control panel | Outside |
| Digital display | Yes |
| Internal light | 1 Horizontal LED |
| External thermometer | No |
| Door- / lid type | Right hinged |
| Self closing / reversible | No/Yes |
| Handle | Outside stainless steel |
| Number of castors, pcs | 2 castors |
| Lock & Key | Yes |

Colour and material

| | |
|---------------------------------|-------|
| Outside colour | White |
| Inside Colour | White |
| Colour and material of door/lid | None |
| Edge trim on shelves / drawers | None |

Features

| | |
|----------------------------------|------------|
| Number of shelves | 5 |
| Adjustable shelves | Yes |
| Shelves material | White wire |
| Max loading per shelf/basket, kg | 30 |
| Large shelves size WxD, mm | White wire |

| | | | |
|-------------|-------------------|------------------|------------|
| Item number | 3132451000GUF390W | Taric goods code | 8418501190 |
| EAN code | 5704704019454 | QTY in 40HQ | 54 |



Short Description

GUF 390 W is a full-door freezer of 293 net liters, with reversible door and sturdy steel handle.

The freezer is spacious and ideal for stocking frozen products in any food producing company, institutions and commercial kitchen.

The freezer cabinet has coated thread shelves, with a maximum capacity of up to 30 kg.

The freezer comes right hinged, but can also be left hinged. The door is solid in full length. Height adjustable legs from 25 to 35 mm.

Key features

- Ventilated Cooling
- Digital controller
- Strong external stainless handle
- 4 strong coated wire shelves
- Reversible door

Measurement drawing

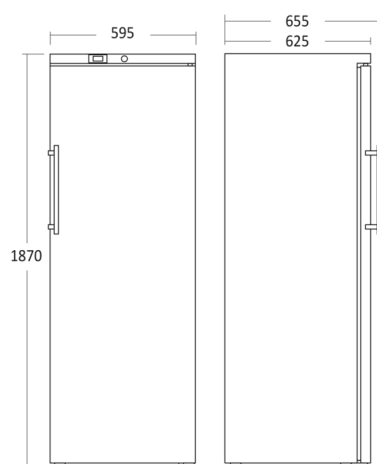

SCANCOOL



Storage Freezer

Scancool, GUF590WB



Dimensions and weight

| | |
|---------------------------------|------------------|
| Product dimensions, HxWxD, mm | 1882 x 775 x 707 |
| Product depth w/handle, mm | 762 |
| Packaging dimensions, HxWxD, mm | 2040 x 840 x 760 |
| Gross volume, L | 510 |
| Net volume, L | 510 |
| Gross- / Net volume, L | 510 / 510 |
| Internal dimensions, HxWxD, mm | x x x |
| Gross- / Net weight, kg | 110 / 101.5 |

Performance and consumption

| | |
|------------------------------------|-------------|
| Energy efficiency class | B |
| Daily Energy Consumption, kWh/24 | 3,77 |
| Annual energy cons. kWh/a | 1376 |
| Energy Efficiency Index (EEl) | 34,53 |
| Refrigeration / freezing technique | Ventilated |
| Climate class | 4 |
| Type of refrigerant / gas gr. | R290a / 110 |
| Bulb Watt, W | 10 |
| Temperature range °C | -15 / -25 |
| NoFrost | Yes |

Installation and power

| | |
|--------------------------|-----------------|
| Voltage / hertz, V/hz | 220-240V / 50hz |
| No. of electrical phases | 1L+N |
| Watt / Ampere, W/A | 250 / |
| Length of Powercord, cm | 180 |

Design and comfort

| | |
|---------------------------|-----------------------|
| Controller | Digital |
| Control panel | Outside |
| Digital display | Yes |
| Internal light | 2 Vertical LED |
| External thermometer | Yes |
| Door- / lid type | Left hinged |
| Self closing / reversible | No/Yes |
| Handle | Outside white plastic |
| Number of castors, pcs | 2 castors |
| Lock & Key | Yes |

Colour and material

| | |
|--------------------------------|-------|
| Outside colour | White |
| Inside Colour | White |
| Edge trim on shelves / drawers | White |

Features

| | |
|--------------------|------------|
| Number of shelves | 6 |
| Adjustable shelves | Yes |
| Shelves material | White wire |



| | | | |
|-------------|---------------------|------------------|------------|
| Item number | 31328610000GUF590WB | Taric goods code | 8418501190 |
| EAN code | 5704704022041 | QTY in 40HQ | 42 |

Short Description

The freezer has coated wire shelves, with a maximum capacity of up to 30 kg.

The freezer is supplied with a right hinge, but can also be left-hinged. The door is solid along its entire length.

The external digital control panel is placed in an ergonomic and user-friendly position.

The GUF590WB is a full-door freezer of 510 net liters with a reversible door and a robust steel handle.

Key features

- GN 2/1 norm - Ventilated Cooling
- Digital controller - temperatur range -18 to -22°C
- Strong external stainless handle
- 4 strong coated wire shelves + 1 in bottom
- Reversible door with stopper and lock
- LED light with switch
- 2 feet in front, 2 castors in back
- Lock & key

Measurement drawing

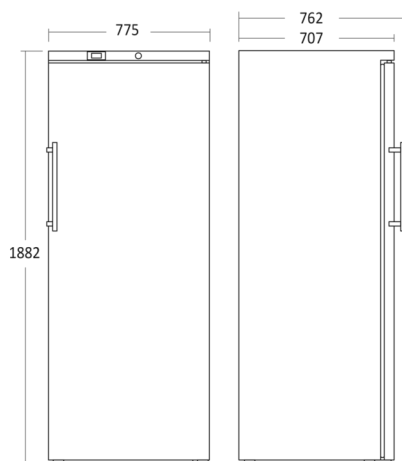

SCANCOOL

scandomestic

- your professional and reliable partner



Scandomestic A/S

Linåvej 20 . DK-8600 Silkeborg

Tel: + 45 7242 5571 . www.scandomestic.dk